

A steam trap is an automatic valve which opens to discharge _____ and _____ but which must prevent waste of _____.

Condensate (& Air)	
Steam	

PANEL 1
Steam Heated
Equipment with
Steam Trap

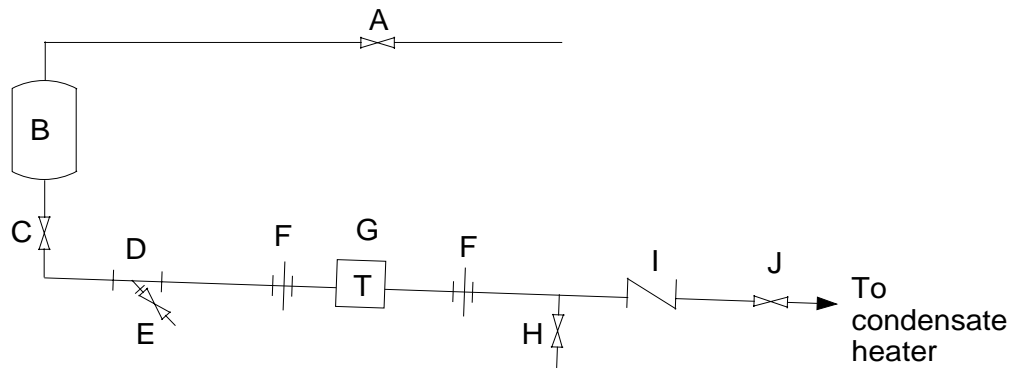

(Panel 1)
 Steam enters this _____-end discharge steam trap system through the steam valve ___(letter) and goes to the steam heated equipment labelled ___(letter) where it changes into _____.

Closed	
A	
B	
Condensate	

(Panel 1)
 Condensate formed in the _____ equipment flows through the upstream shut-off valve ___(letter) and through the _____ which is labelled ___(letter) where dirt and scale are removed.

Steam-heated	
C	
Strainer	
D	

(Panel 1)
 From the strainer the condensate goes through a union (F) then through the _____ (G), through another union (F), then the check valve _____(letter), then the downstream shut-off valve ___(letter) and out of the system.

Steam Trap	
I	
J	

(Panel 1)

Draw a solid line(—) along the path of the steam to where it condenses.

Draw a dashed line(- -) from the area where the condensate is formed to the point where it leaves the system

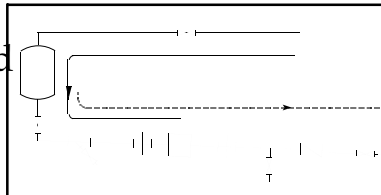

Draw on panel

(Panel 1)

Next to (A) and (B) on the panel, write the name of the parts which they represent.

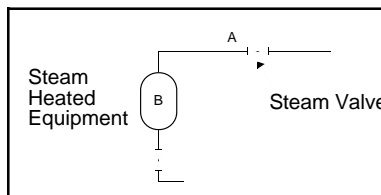

Write on panel

(Panel 1)

Write the name of the parts labelled (C), (D), (G), (I), and (J) through which the condensate flows.

- C. Upstream shut-off valve
- D. Strainer
- G. Steam trap
- I. Check valve
- J. Downstream shut-off valve

Write on panel

(Panel 1)

Write the names of parts labelled (E), (F), and (H).

- E. Strainer valve
- F. Union
- H. Test valve

Write on panel

(Panel 1)

Parts labelled (F) are unions which make it possible to quickly remove the _____ from the piping.

Steam Trap

A steam trap is operating correctly if it is _____ (what?) and discharges _____ and _____ and prevents waste of _____.

Hot Condensate Air Steam	
-----------------------------------	--

PANEL 2

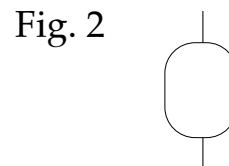
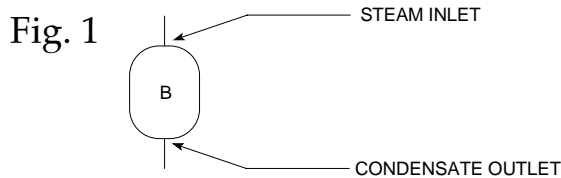

(Panel 2 - Figure 1)

Steam flows through piping and the steam valve (valve symbol = ) to get to the steam heated equipment.

Sketch the piping and steam valve on the panel.

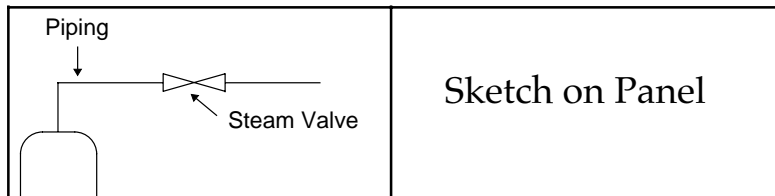

Sketch on Panel

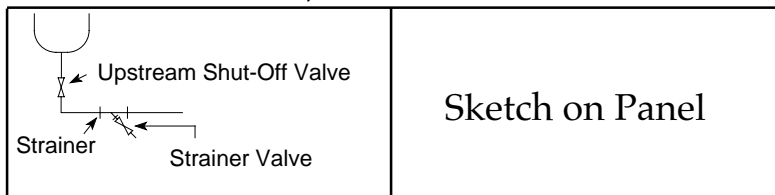

(Panel 2 - Figure 1)

Sketch the condensate removal piping from equipment (A). Show the upstream shut-off valve, the strainer (strainer symbol = ) and the strainer valve.

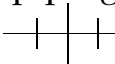

Sketch on Panel

(Panel 2 - Figure 1)

Complete the condensate removal piping for an open-end discharge system - show unions (union symbols = ) and steam trap (steam trap symbol = ) .

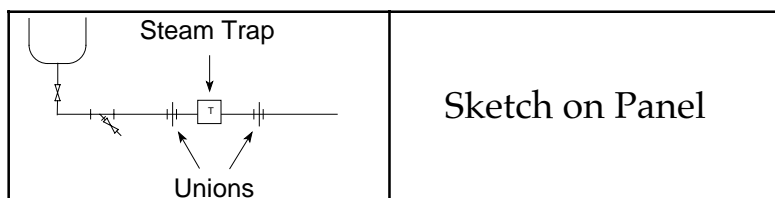

Sketch on Panel